



A Radiotelegraph Key In the Marconi Tradition

The Cabot Tower
on Signal Hill
St. John's, NF

WB9LPU photo



December 12, 2001 marks the 100th anniversary of one of the extraordinary events that set the tone for the 20th century. This event was the first successful attempt to span the Atlantic ocean with the recently-discovered radio waves. On December 12, 1901, Guglielmo Marconi, using a kite to hold up his antenna wire, received the pre-arranged signal consisting of three dots, "S" in Morse code. The world suddenly shrank again.

In the summer of 2001, my wife and I had the opportunity to visit the site of this achievement, the city of St. John's, Newfoundland. We enjoyed the hospitality of the people, the beauty of the country, and the privilege of visiting this historic locale.



This important event took place on Signal Hill in St. John's, Newfoundland, at that time a British colony. This is a view of the city of St. John's and its harbor from Signal Hill, near the site of the historic reception. In the foreground is the Field Day setup of SONRA, the Society of Newfoundland Radio Amateurs, whose club station is housed in the Cabot Tower. They were very hospitable and let me look over their shoulders during their operations. (Unfortunately, that night a "breeze" from the Atlantic Ocean ended their operation by removing the tent and scattering the contents.)

Whenever we visit an interesting place, I try to find some local material to use in building a telegraph key. I decided to look around for some native stone for the base of a key which would be a replica of the type of key made by the Marconi Company early in the century.

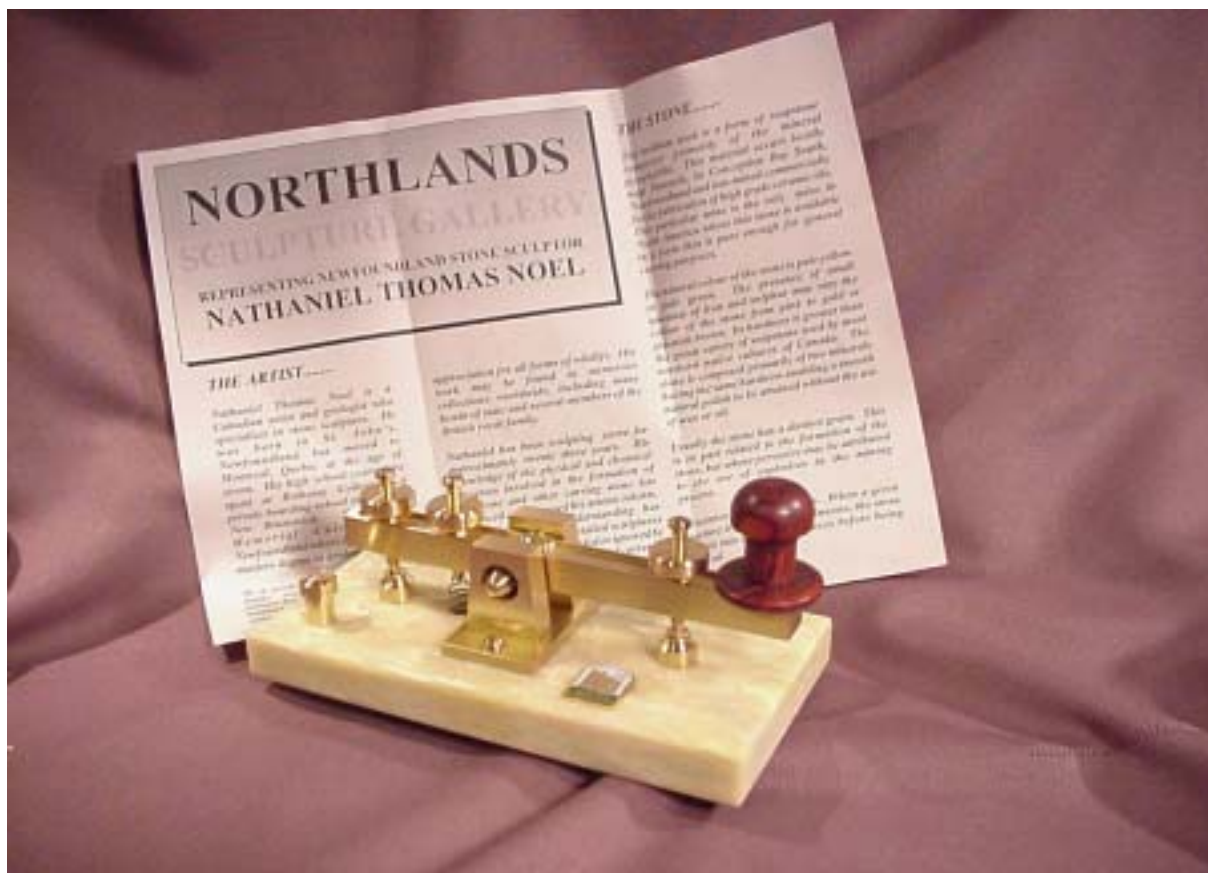

While taking a walk, I had the good fortune to come upon the Northlands Sculpture Gallery in the center of St. John's. This is the workplace and showplace of Mr. Nathaniel Thomas Noel, a artist who works with the native soapstone which, until recently, was quarried on the island of Newfoundland. The gallery contained some exquisite examples of his artistry. With some misgivings, I showed him a picture of one of my homebrew telegraph keys and inquired as to where I could obtain some soapstone to use for the base of my proposed key. My request must of have intrigued him, because he quickly offered to give me some of his prize stock (in exchange for a cup of coffee at Tim Horton's; I offered to throw in a picture of the finished key). Three days later, I was in possession of three beautiful slabs of Newfoundland soapstone (Air Canada was going to love me). I also learned some of the lore of soapstone and the ways to cut, drill, and polish it.

As soon as we got home, I headed to one of my favorite web sites, Tom Perera's (W1TP) Telegraph Museum (<http://www.w1tp.com>) to look at some examples of keys by the Marconi company. Here are two that I found in Tom's museum:



The upper picture shows an original Marconi key from the early teens. It is now in the collection of Pete Malvasi, W2PM. The lower picture is of a museum reproduction, constructed by W2CUV, of the key from the Olympia, the sister ship of the Titanic. These pictures, and a number of others from elsewhere on the net, gave me an idea of the distinguishing features of a Marconi wireless key. I will comment on these a bit later.

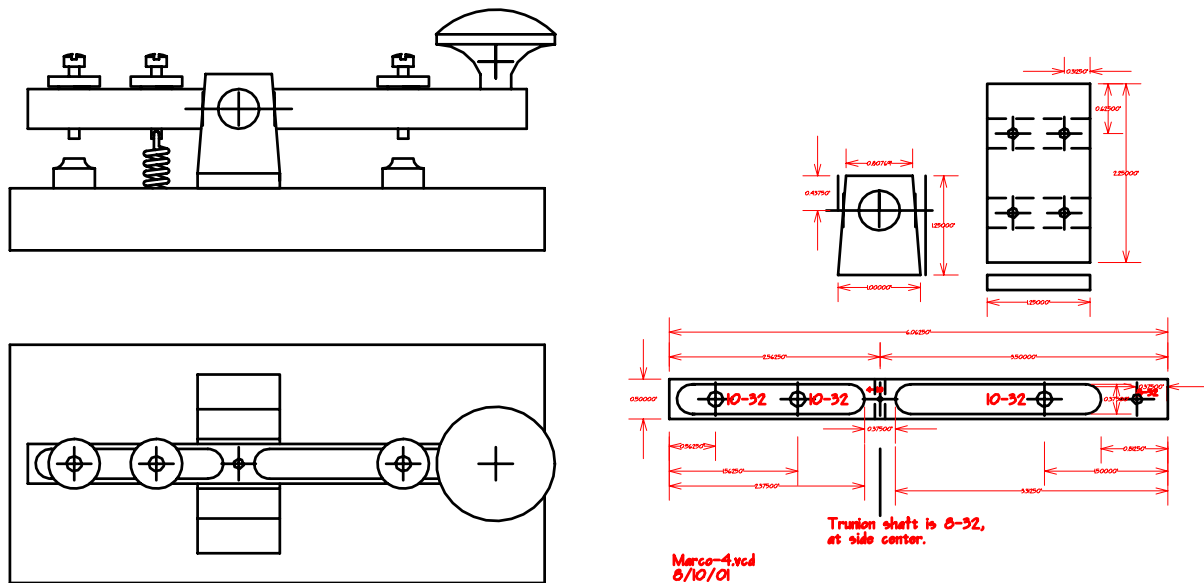

The next step was to draw up some plans to get the general design worked out. I didn't want to make a copy of an existing key, so I decided to incorporate all of the features that I could into an original design that was fairly consistent with the Marconi keys of the day. The final design was for a key somewhat smaller than some of the massive spark keys, but it would still be big enough that you really felt that you were "pounding brass." The drawing above is incomplete, and there was some further evolution as construction went on.

Special "Marconi-like" design features include the use of a square lever with no bends or taper, but with a milled recess in the top. The bearing blocks are trapezoidal and use ball bearings. Lever tension is provided by a "pull-down" spring in front of the trunion (which is very narrow). The front limit stop and the contacts are on raised, tapered bosses attached directly to the base of the key. The knob is a mushroom type. Binding posts are not shown in this figure. So while this key is not an exact replica of any existing key, it does incorporate many common features.

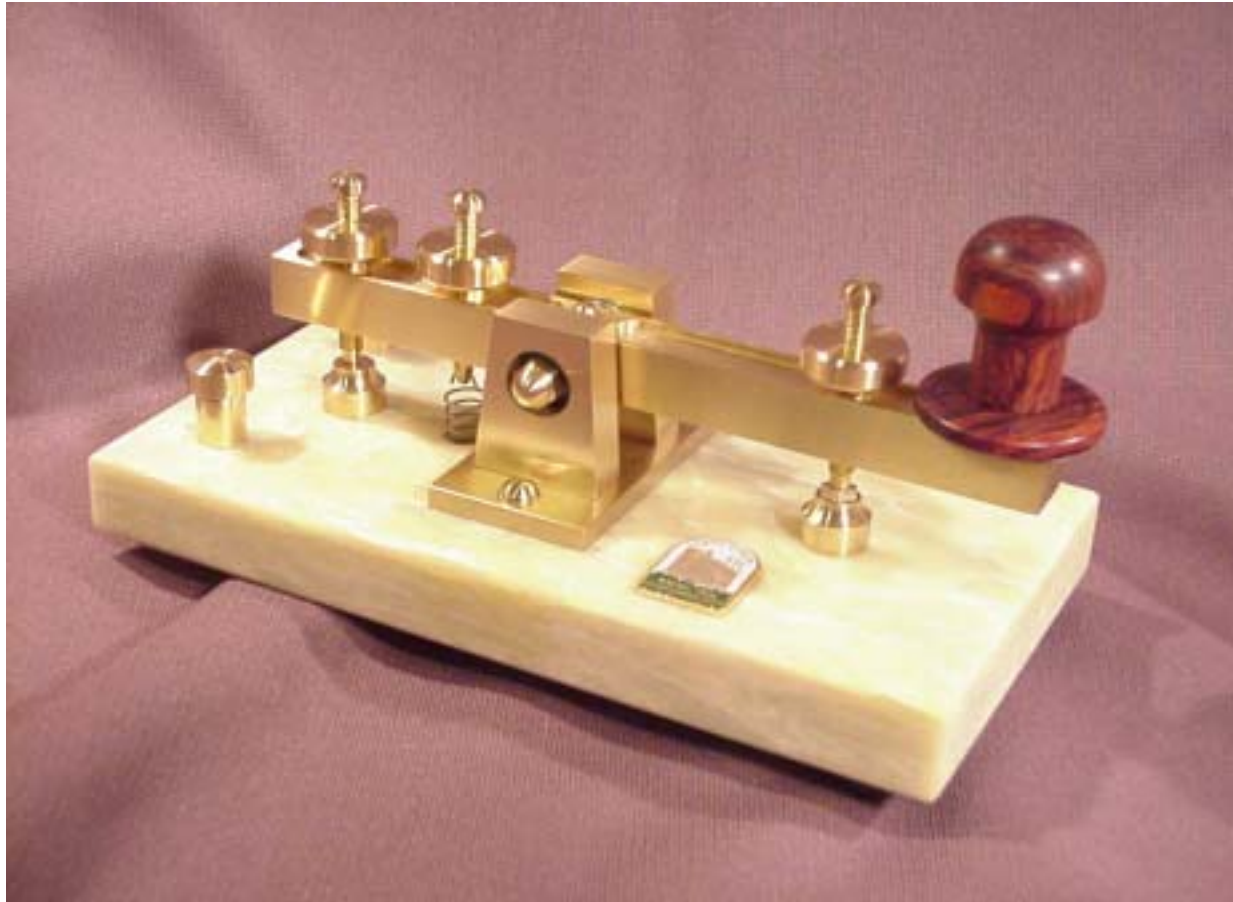

So here is the final product. It is mounted on a base of Newfoundland soapstone approximately 3/4" thick. The stone was cut to size (6-1/2" x 3") with a hacksaw, and the edges were trued up using a graded series of grits of wet-strength sandpaper. The top and bottom surfaces were finished in a similar way, and a slight chamfer was added to the top surface as a finishing touch.

All mechanical parts except for the spring and ball bearings are C360 brass. The adjusting screws were made from 10-32 brass round-head machine screws. The knob is turned from a tropical wood called cocobolo. The metal parts were given two coats of an industrial lacquer to preserve their brightness. As a final touch, a small enameled icon showing the Cabot Tower on Signal Hill was added.

Some details of the construction are shown on the next two pages.



The rear of the lever is squared off, and the knob is mounted directly to it. A knob skirt was added to make the key feel more comfortable in use. The contact screw has a lock nut, and the lower contact is replaceable.



The front rest-position adjustment screw contacts a brass stop. Both it and the tension adjustment have lock nuts. The binding posts are mounted at the front of the key.



Close-up view of the bearings and trunion, mounted in tapered bearing blocks. Note the milled-out section on the top of the lever. This appears to be characteristic of Marconi designs. A nice touch, but difficult to do well. My round-ended milling is a compromise approach.



All electrical connections are made via buss-bars, as appeared to be standard practice at the time (and still is in some cases).



Thanks again to Mr. Noel for his generous gift that ties this key to the historic locale that it is meant to celebrate.



This view of the Cabot Tower is from the actual spot where the first signals were received. Many thanks to the people of Newfoundland and Canada, who continue to maintain this historic site. And thanks also to the members of SONRA for their friendliness on our visit. (Their 160 meter inverted vee antenna is not visible in this picture).

There are still several pieces of soapstone left. One will become the base of a new bug, and one will support an iambic paddle at some time in the future. Another will host a smaller Marconi-type key. Each time I use these keys I will remember this trip to the spot in North America nearest to the continent of Europe, a spot that was made nearer still by the genius and persistence of the remarkable Mr. Marconi.

Copyright Richard A. Meiss, WB9LPU
Speedway, Indiana
October, 2001